

▼ Shown from left to right: ZU4304MB, ZU4420SB-H, ZU4304PB-K



**Z** Tough.  
Dependable.  
Innovative.  
**ZCLASS**

- Features **Z-Class** high-efficiency pump design; higher oil flow and bypass pressure, cooler running and requires 18% less current draw than comparable pumps
- Powerful 1.7 hp universal electric motor provides high power-to-weight ratio and excellent low-voltage operating characteristics
- High-strength, molded composite shroud protects motor and electronics, while providing an ergonomic, non-conductive handle for easy transport
- Low-voltage pendant provides additional safety for the operator (remote control units)

**Pro-Series pump only**

- LCD readout provides pressure and a number of diagnostic and readout capabilities never before offered on a portable electric pump
  - pump usage information, hour and cycle counts
  - self-test, diagnostic and read-out capabilities
  - pressure readout and auto-mode pressure settings

▼ **COMMON PUMP MODELS**

For technical information and other options see next page.

<b>BASIC PUMP TYPES</b>	
Select the model that suits your application. For special requirements contact your Enerpac office.	
<b>Manual Valve</b>	
<ul style="list-style-type: none"> <li>• Ideal choice for most applications</li> <li>• Manual valve control, for single-acting or double-acting applications</li> <li>• Motor control on shroud</li> </ul>	
<b>Manual Valve with Pendant</b>	
<ul style="list-style-type: none"> <li>• For light production and lifting applications</li> <li>• Manual valve control for single-acting or double-acting cylinders</li> <li>• Low-voltage control pendant with 10-ft. cord for remote motor operation</li> </ul>	
<b>Dump Valve</b>	
<ul style="list-style-type: none"> <li>• Ideal for punching, crimping and cutting</li> <li>• For use when load-holding is not required</li> <li>• Low-voltage control pendant with 10-ft. cord controls valve and motor</li> </ul>	
<b>Solenoid Valve</b>	
<ul style="list-style-type: none"> <li>• Ideal for lifting applications and where remote control is required</li> <li>• Motor runs continuously on pumps with VE33 and VE43 valves. With VE32 valve, motor only runs during the advance function, while holding and retracting, the motor is off</li> <li>• Low-voltage control pendant with 10 ft. cord for remote motor and valve operation</li> </ul>	



◀ Designed to be tough, the ZU4-Series with steel reservoirs will take the abuse of today's construction sites.

# ZU-Series, Electric Pumps



## Z-Class – A Pump For Every Application

Patented Z-Class pump technology provides high

by-pass pressures for increased productivity—important in applications using long hose runs and high pressure-drop circuits, like heavy lifting or certain double-acting tools.

Enerpac ZU4 Hydraulic Pumps are built to power small to large-sized cylinders or hydraulic tools, or wherever high-speed, intermittent duty, remote hydraulic power is needed.

### Classic Electric Pump

- The *Classic* has traditional electro-mechanical components (transformers, relays and switches) in place of solid-state electronics. The *Classic* delivers durable, safe

and efficient hydraulic power for demanding markets like construction, post-tensioning and foundation repair.

### Standard Electric Pump

- For applications that do not require digital display features of the Premium Pump. Available in all manual or jog versions.

### Pro Electric Pump

- Digital (LCD) display features a built-in hour meter and shows self-diagnostic, cycle-count and low voltage warning information.

Pressure can also be displayed when the pump is equipped with an optional pressure transducer.



## ZU Series



Reservoir Capacity:

**1.0-10.0 gal.**

Flow at Rated Pressure:

**60 in<sup>3</sup>/min.**

Motor Size:

**1.7 hp**

Maximum Operating Pressure:

**10,000 psi**

Pump Type	Used with Cylinder		Valve Function			Valve Type <sup>2)</sup>	Pump Control	Usable Oil Capacity (gal)	Model Number 115 VAC <sup>3)</sup> 1 Phase			Pro Product Weight With Oil <sup>4)</sup> (lbs)
									Classic	STD Electric	Pro Electric	
	●		●		●	VM22	Manual	1.0	ZU4704RB	ZU4704MB	ZU4704LB	59
	●		●		●	VM22	Manual	2.0	ZU4708RB	ZU4708MB	ZU4708LB	69
	●		●	●	●	VM33	Manual	2.0	ZU4308RB	ZU4308MB	ZU4308LB	70
	●		●	●	●	VM33	Manual	5.0	ZU4320RB	ZU4320MB	ZU4320LB	109
		●	●	●	●	VM43	Manual	2.0	ZU4408RB	ZU4408MB	ZU4408LB	70
		●	●	●	●	VM43	Manual	5.0	ZU4420RB	ZU4420MB	ZU4420LB	109
	●		●		●	VM32	Remote (Man.)	1.0	ZU4704PB	ZU4204JB	ZU4204KB	60
	●		●		●	VM32	Remote (Man.)	2.0	ZU4708PB	ZU4208JB	ZU4208KB	70
	●		●		●	VM32	Remote (Man.)	5.0	ZU4720PB	ZU4220JB	ZU4220KB	109
	●		●	●	●	VM33	Remote (Man.)	2.0	ZU4308PB	ZU4308JB	ZU4308KB	71
		●	●	●	●	VM43	Remote (Man.)	2.0	ZU4408PB	ZU4408JB	ZU4408KB	71
		●	●	●	●	VM43	Remote (Man.)	5.0	ZU4420PB	ZU4420JB	ZU4420KB	110
	●		●		●	VE32D	Remote	1.0	N/A	N/A	ZU4104DB	63
	●		●		●	VE32D	Remote	2.0	N/A	N/A	ZU4108DB	73
	●		●		●	VE32D	Remote	5.0	N/A	N/A	ZU4120DB	112
						-	-	-	-	-	-	-
						-	-	-	-	-	-	-
						-	-	-	-	-	-	-
	●		●	●	●	VE32	Remote	1.0	N/A	N/A	ZU4204SB	63
	●		●	●	●	VE32	Remote	2.0	N/A	N/A	ZU4208SB	73
	●		●	●	●	VE33	Remote	2.0	N/A	N/A	ZU4308SB	85
		●	●	●	●	VE43	Remote	2.0	N/A	N/A	ZU4408SB	85
		●	●	●	●	VE43	Remote	5.0	N/A	N/A	ZU4420SB	124
						-	-	-	-	-	-	-
						-	-	-	-	-	-	-
						-	-	-	-	-	-	-

<sup>1)</sup> CE conformity marking only applies to pumps with an "E" suffix. "E" voltage versions also meet all requirements of the European EMC-Directive.

<sup>2)</sup> See valves section for technical information on valve types.

<sup>3)</sup> See custom order matrix for other voltage options.

<sup>4)</sup> Subtract 3 lbs. for STD Electric models.

# ZU Series, Specifications and Dimensions

ZU4 Performance							
Motor Size	Output Flow Rate (in <sup>3</sup> /min)				Motor Electrical Specification	Sound Level	Relief Valve Adjustment Range
	(hp)	100 psi	700 psi	5000 psi			
1.7	700	535	76	60	115-1-50/60 230-1-50/60	85-90	2,000-10,000

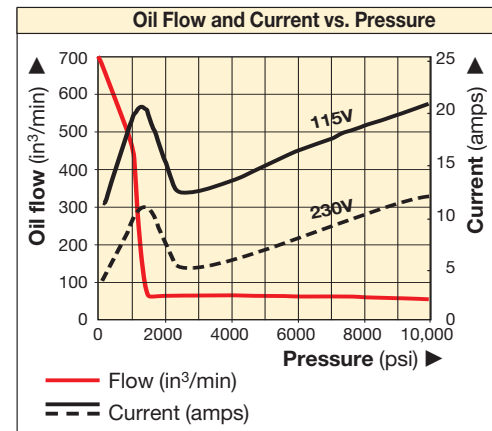

## ZU-4 Series with 1 and 2 gallon reservoirs

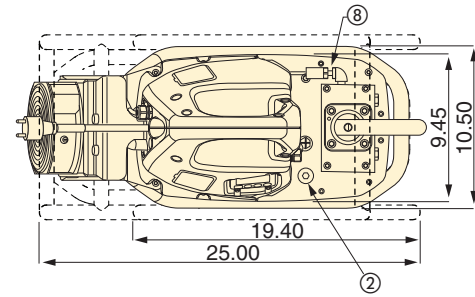
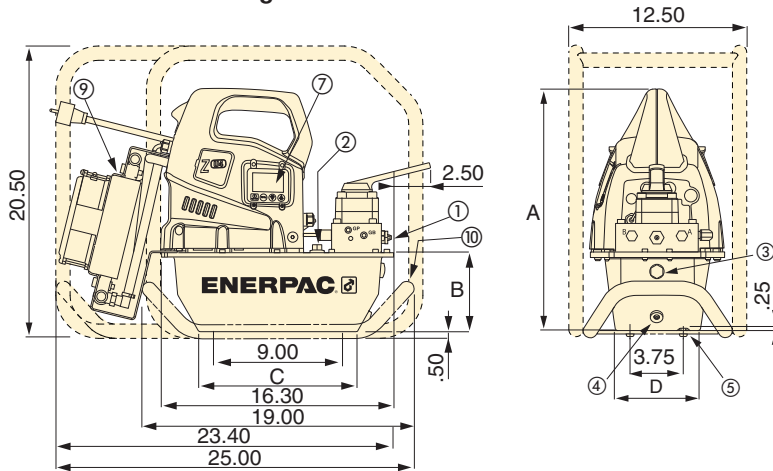

## ZU-4 Series with 2.5, 5.0 and 10.0 gallon reservoirs

(Left view shown without side handle)

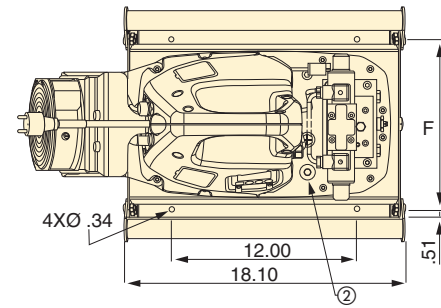
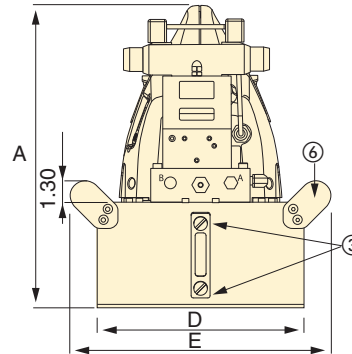
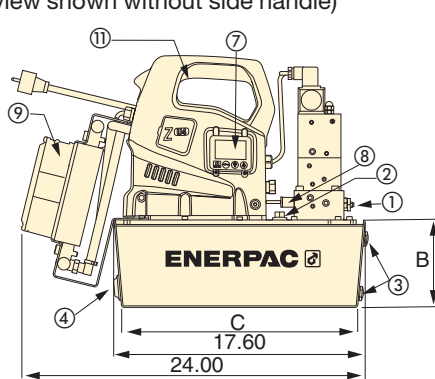

- ① User adjustable relief valve
- ② Oil fill port, SAE#10
- ③ Oil level sight gauge
- ④ Oil Drain, 1/2" NPTF
- ⑤ M8 x 1.25
- ⑥ Handles on all 2.5, 5.0, and 10.0-gallon reservoirs

### Factory installed features and options

- ⑦ Back-lit LCD Electric
- ⑧ Pressure transducer
- ⑨ Heat exchanger
- ⑩ Skid bar
- ⑪ Handle guard installed on all 2.5, 5, and 10-gallon reservoirs
- ⑫ Reservoir handles included on all 2.5, 5 and 10-gallon pumps



Increased output flow and extended brush life increase productivity for post-tensioning applications.

Usable Reservoir Capacity (gal)	Pump Dimensions (in)					
	A	B	C	D	E	F
1.0	16.7	5.6	11.0	6.0	-	-
2.0	16.7	5.6	11.0	8.1	-	-
2.5	17.3	6.2	16.5	12.0	15.1	11.0
5.0	18.3	7.1	16.5	16.6	19.7	15.6
10.0	21.7	10.6	15.7	19.9	22.7	18.9

## CUSTOM BUILD YOUR ZU4 SERIES PUMP

If the ZU4 Series pump that would best fit your application cannot be found in the chart on page 91, you can easily build your custom ZU4 Series pump here.

▼ This is how a ZU-Series pump model number is built up:



1	2	3	4	5	6	7	8	
Product Type	Motor Type	Flow Group	Valve Type	Reservoir Size	Valve Operation	Voltage	Options and Accessories	

### 1 Product Type

Z = Pump Series

### 2 Motor Type

U = Universal electric motor

### 3 Flow Group

4 = 60 in<sup>3</sup>/min @ 10,000 psi

### 4 Valve Type (see page 128 for more details)

- 1 Dump (VE32D)
- 2 3 way/2 position manual or electric (VM32 or VE32)
- 3 3 way/3 position manual or electric (VM33 or VE33)
- 4 4 way/3 position manual or electric (VM43 or VE43)
- 6 3 way/3 position locking manual w/po check (VM33-L)
- 7 3 way/2 position manual (VM22)
- 8 4 way/3 position locking manual w/po check (VM43-L)
- 9 4 way/3 position manual w/power seating (VM43-LPS)
- 10 3 way/3 position manual, Venturi-Valve (VM33VAC)
- 11 3 way/3 position electric, Venturi-Valve (VE33VAC)

### 5 Reservoir Size (useable capacity)

- 04 = 1.0 gallon
- 08 = 2.0 gallon
- 10 = 2.5 gallon (includes side handles)
- 20 = 5.0 gallon (includes side handles)
- 40 = 10.0 gallon (includes side handles)

### 6 Valve Operation

- D = Dump (solenoid valve w/pendant and LCD Electric)
- J = Jog (manual valve w/pendant and Standard Electric (i.e. w/o LCD))
- K = Jog (manual valve w/pendant and LCD Electric)
- L = Manual valve w/LCD Electric (w/o pendant)
- P = Manual valve w/pendant and classic electric (i.e. w/o LCD)
- R = Manual valve w/Classic electric (i.e. w/o LCD) [w/o pendant]
- M = Manual valve w/Standard Electric (i.e. w/o LCD) [w/o pendant]
- S = Solenoid valve w/pendant and LCD Electric

### 7 Voltage

- B = 115V, 1 ph, 50/60Hz
- E = 208-240V, 1 ph, 50/60 Hz (w/European plug and CE EMC compliant)
- I = 208-240V, 1 ph, 50/60 Hz (w/NEMA 6-15 plug)

### 8 Options and Accessories (see page 94 for possibilities)

- F = Filter
- G = 0-15,000 psi gauge (2½")<sup>1)</sup>
- H = Heat exchanger
- K = Skidbar (1 and 2 gallon reservoirs only)
- L = Level/temp switch<sup>2)3)</sup>
- N = No reservoir handles (includes lifting eyes)
- R = Roll cage
- T = Pressure transducer<sup>2)</sup>
- U = Foot switch

<sup>1)</sup> Pressure gauge not available on pump models with pressure transducer

<sup>2)</sup> These options require LCD electric

<sup>3)</sup> Not available on 1 and 2 gallon reservoirs

## ZU Series



Reservoir Capacity:  
**1.0-10.0 gal.**

Flow at Rated Pressure:  
**60 in<sup>3</sup>/min.**

Motor Size:  
**1.7 hp**

Maximum Operating Pressure:  
**10,000 psi**



### Speed Chart

To determine how a "Z" pump will operate your cylinder, see the Pump/Cylinder Speed Chart in the "Yellow Pages".

Page: **283**



### Ordering Example

**Model Number:**  
**ZU4408LB-HKT**

ZU4408LB-HKT is a 60 in<sup>3</sup>/min at 10,000 psi pump with a 4-way, 3-position manual valve, a 2 gal. (8-liter) reservoir, operates on 115V, 1ph, 50/60 Hz and is specified with optional LCD electrical panel, heat exchanger, pressure transducer and skid bar.



### Torque Wrench Pumps

System matched air and electric pumps provide control to operate Enerpac Torque Wrenches.

Page: **212**



### Assisted-Return Pumps

To improve productivity and plunger retraction, Enerpac offers valve configurations designed to accelerate your cylinder retraction speeds. ZU4 and ZE-Series pumps feature Venturi valve technology to facilitate the faster return of single-acting gravity return cylinders. See details on [www.enerpac.com](http://www.enerpac.com)



## Pressure Transducer\*

- More durable than analog gauges (against mechanical and hydraulic shock)
- More accurate than analog gauges (0.5% full scale of pump)
- Calibration can be fine-tuned for certification
- “Set pressure” feature turns off motor at user defined pressure (or shifts valve to neutral on models with VE33/VE43 valves)
- Display pressure in psi, bar, or MPa

\* Requires LCD Electric

Accessory Kit Model Number	Adjustable Pressure Range (psi)	Switch-point repeatability	Dead-band (psi)
ZPT-U4 *	50-10,000	± 0,5%	50

\* Add suffix **T** for factory installation.

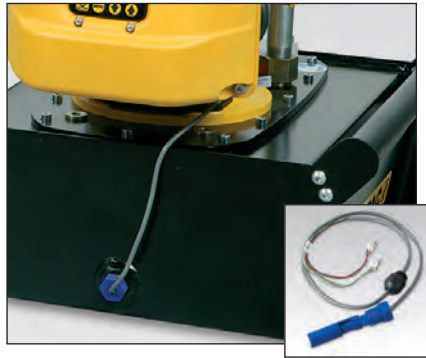

## Level/Temperature Switch

- Ensures feedback on pump oil level and temperature
- Drop-in design allows for easy installation to pump reservoir
- Plugs directly into pump electrical enclosure
- Built-in thermal sensing shuts off pump when unsafe operating temperature is reached
- Oil level switch shuts down pump before oil reaches an unsafe operating level

Model Number	Operating Temperature (° F)	Maximum Pressure (psi)	Weight (lbs)
ZLS-U4	40-230	150	.11

\* Add suffix **L** for factory installation.



## Hoses

Enerpac offers a complete line of high-quality hydraulic hoses. To ensure the integrity of your system, specify only Enerpac hydraulic hoses.

Page: 132



## Gauges

Minimize the risk of overloading and ensure long, dependable service from your equipment. Refer to the System Components section for a full range of gauges.

Page: 131



## Foot Switch

- Hands-free remote control on solenoid dump and 3-position valves
- With 10-foot cord

Accessory Kit No.	Can be used on ZU4 Pumps with
ZCF-2 *	Solenoid VE-Series valves

\* Add suffix **U** for factory installation.



## Roll Cage

- Protects pump
- Provides greater pump stability

Accessory Kit Number	Fits on Reservoir
ZRC-04 *	1 and 2 gallon <sup>1)</sup>
ZRC-04H *	1 and 2 gallon <sup>2)</sup>
ZRB-10 *	2.5 gallon
ZRB-20 *	5 gallon
ZRB-40 *	10 gallon

\* Add suffix **R** for factory installation.

<sup>1)</sup> Without heat exchanger <sup>2)</sup> With heat exchanger

Ordering Example:  
Model No. ZU4208BB-QR



## Skidbar\*

- Provides easy two-hand lift
- Provides greater pump stability on soft or uneven surfaces
- Also available as an add-on kit (model number SBZ-4)

\* 1 and 2-gallon reservoirs only

Accessory Kit No.	For ZU-Series Pumps with Reservoir	Wt. (lbs)
SBZ-4 *	1-2 gal. w/o heat exchanger	4.9
SBZ-4L *	1-2 gal. with heat exchanger	5.5

\* Add suffix **K** for factory installation.

# ZU-Series Factory Installed Options and Accessories



## ZU4-Series Options

Accessory Kits can be installed by the customer.

See chart below for all possible options on ZU4-Series pumps:

- Classic Electric,
  - Standard (STD) Electric (no LCD)
  - Pro Electric (with LCD).
- Refer to page 93 for ordering matrix.

ZU4-Series Options	Factory Installed			Accessory Kits		
	Classic Electric	Standard Electric	Pro Electric	Classic Electric	Standard Electric	Pro Electric
Return Line Filter	F	F	F	ZPF	ZPF	ZPF
Skid Bar <sup>1)</sup>	K	K	K	SBZ	SBZ	SBZ
Roll Cage	R	R	R	ZRC	ZRC	ZRC
Heat Exchanger	H	H	H	ZHE	ZHE	ZHE
Pressure Gauge	G	G	G	G	G	G
Pressure Transducer	-	-	T	-	-	ZPT-U4
Level/Temperature Switch	-	-	L	-	-	ZLS-U4
Foot Switch	-	-	U	-	-	ZCF-2

<sup>1)</sup> Skid Bar not in combination with Roll Cage.

## ZU Series



Reservoir Capacity:

**1.0-10.0 gal.**

Flow at Rated Pressure:

**60 in<sup>3</sup>/min.**

Motor Size:

**1.7 hp**

Maximum Operating Pressure:

**10,000 psi**



### Return Line Filter

- 25 micron nominal filter removes contaminants from return oil flow before allowing it back into tank
- Internal by-pass valve prevents damage if filter is dirty
- With maintenance indicator

Accessory Kit Model Number	Maximum Pressure (psi)	Maximum Oil Flow (GPM)	By-pass Setting (psi)
ZPF *	200	12.0	25

\* Add suffix F for factory installation.



### Heat Exchanger

- Removes heat from the bypass oil to provide cooler operation
- Stabilizes oil viscosity, increasing oil life, and reduces wear of pump and other hydraulic components

Accessory Kit No. *	Can be used on
ZHE-U115	115V pumps
ZHE-U230	230V pumps

\* Add suffix H for factory installation.



## Heat Exchanger

- Extends system life
- Stabilizes oil temperature at a maximum of 130° F at 70° F ambient temperature.

Do not exceed maximum oil flow and pressure ratings. Heat exchanger is not suitable for water-glycol or high water based fluids.

Thermal Transfer *	Maximum pressure (psi)	Maximum oil flow (GPM)	Voltage (VDC)
Btu/h	900	7.0	12

\* At GPM at 70 °F ambient temperature.