



MOD: KDCF-3500

INSTRUCTION MANUAL FOR 1 MICRON CANISTER FILTER FOR DUST COLLECTOR

WARRANTY INFORMATION

PROOF OF PURCHASE

Please keep your dated proof of purchase for warranty and servicing purposes.

REPLACEMENT PARTS

Replacement parts for this unit are available at our authorized KING CANADA service centers across Canada. For servicing, contact or return to the retailer where you purchased your product along with your proof of purchase.

LIMITED TOOL WARRANTY

KING CANADA makes every effort to ensure that this product meets high quality and durability standards. KING CANADA warrants to the original retail consumer a 2-year limited warranty as of the date the product was purchased at retail and that each product is free from defects in materials. Warranty does not apply to defects due directly or indirectly to misuse, abuse, negligence or accidents, repairs or alterations and lack of maintenance. KING CANADA shall in no event be liable for death, injuries to persons or property or for incidental, special or consequential damages arising from the use of our products. To take advantage of this warranty, the product or part must be returned for examination by the retailer. Shipping and handling charges may apply. If a defect is found, KING CANADA will either repair or replace the product.

PARTS DIAGRAM & PARTS LISTS

Refer to the Parts section of the King Canada web site for the most updated parts diagram and parts list.

Getting to know your Canister Filter (Fig.1)

- A) Canister Filter assembly
- B) Handle steel bar & assembly hardware
- C) Handle & assembly hardware
- D) Lock knobs

Assembly Steps (Fig.2)

Step 1

Mount the handle steel bar to the threaded shaft on top of the canister filter. The assembly order is as follows; first thread hex. nut onto threaded shaft, place spring washer, handle steel bar, spring washer and finally thread the last hex. nut and tighten both hex. nuts against each other to secure.

Step 2

Mount handle upside down to handle steel bar using the washer, spring washer and hex. nut and tighten securely. Mounting handle upside down makes it easier to turn handle once the canister filter is mounted on a dust collector housing.

Installation (Fig.3)

Place the assembled canister filter over the dust collector housing. Make sure the canister filter is pushed down all the way. Secure in place using the 4 threaded lock knobs.

Usage/Maintenance

After considerable use, there will be dust build-up in the filter which will reduce long term efficiency. The top handle is used to dislodge dust build-up in the filter, turning the handle rotates rubber flaps which dislodge dust and increase long term efficiency. Periodically clean the filter with compressed air.

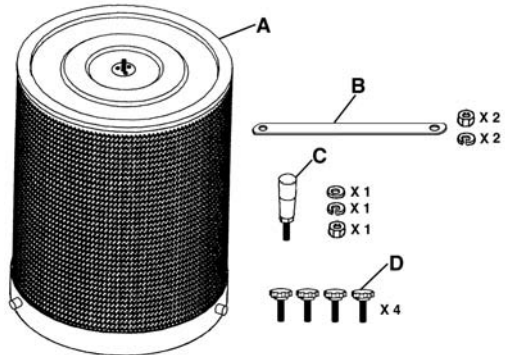

FIGURE 1

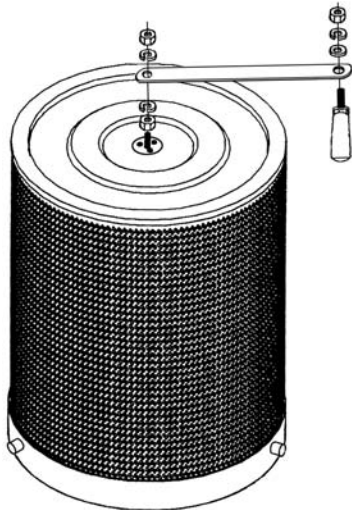

FIGURE 2

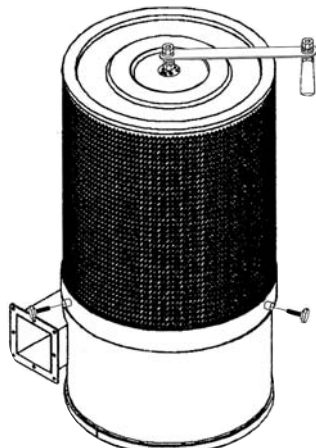

FIGURE 3